

aeris.global[®]
an aeris holding

aquaturbo[®] AER-AS

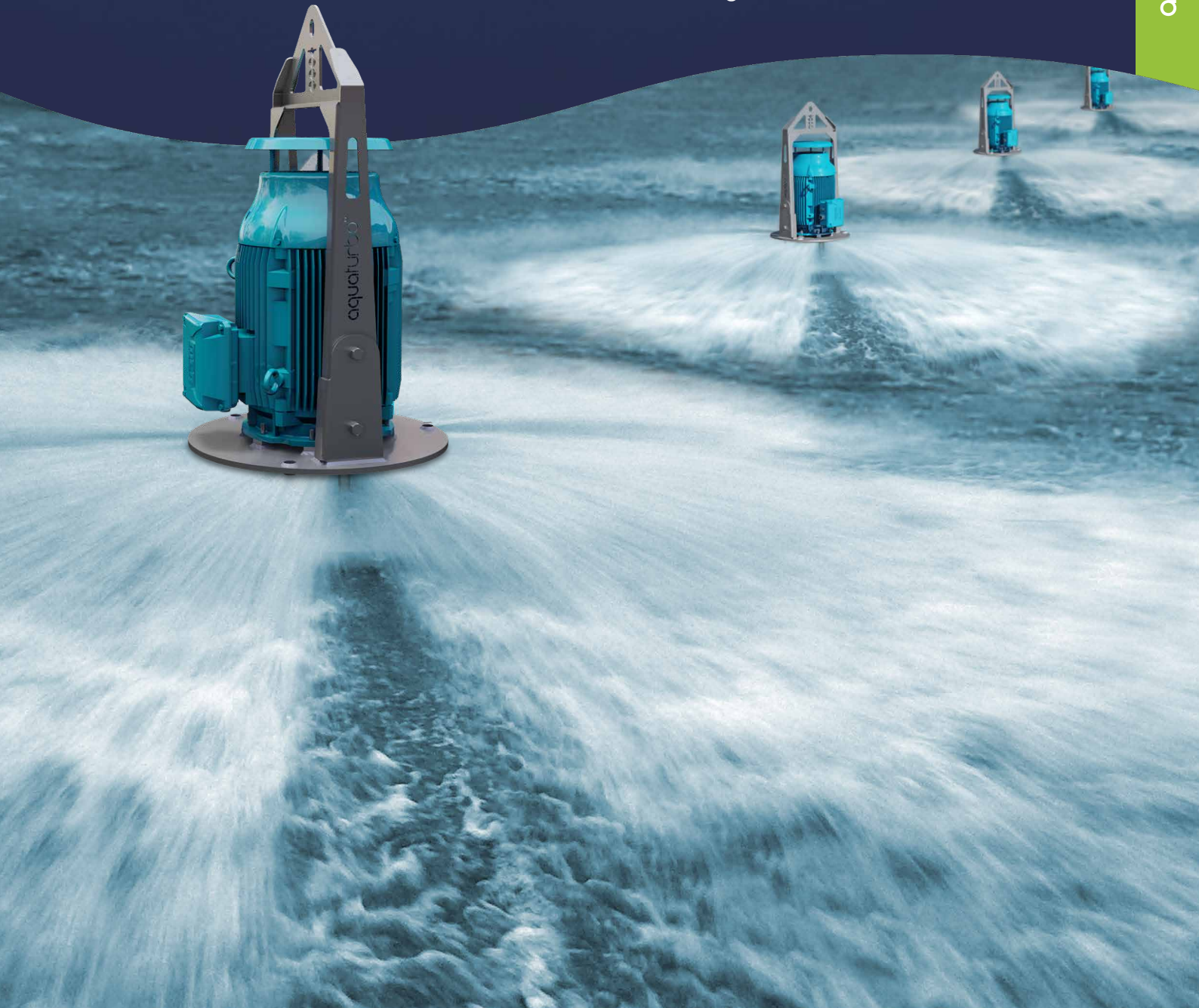

aquaturbo[®] **AER-AS**

Floating Surface Aerator

www.aeris.global



Nothing aerates like aquaturbo®

aquaturbo® **AER-AS** Surface Aerator stands the test of time

Many aerators have come and gone over the past 40-years but aquaturbo® **AER-AS** Surface Aerator remains the tried-and-true market leader. Performance in the field is unsurpassed by any other surface aerator, in fact any other aerator, in the world.

Tick the boxes and compare aquaturbo® **AER-AS** with any other aeration technology. When all factors are considered aquaturbo® **AER-AS** comes out on top every time.

- ✓ Outstanding efficiency in wastewater
- ✓ Zero drop-off in efficiency over time
- ✓ Exceptional mixing and oxygen dispersion
- ✓ Adaptable to suit any water level
- ✓ Water level does not affect efficiency
- ✓ Suitable for any lagoon, tank or ditch; any shape, any size
- ✓ Suitable for fixed and variable frequency operation
- ✓ Unparalleled water-cooling capabilities – adjustable rate
- ✓ Low-noise operation
- ✓ Low-aerosol production and low-odour migration
- ✓ Ease of installation – Even whilst the plant remains online
- ✓ Ease of maintenance
- ✓ Simplicity of design and operation
no gearbox, no submerged bearings, no mechanical seals, no oil, no variable speed drives, no blowers, no pipework or valves
- ✓ Long service life - no consumable parts, no opposing wear surfaces
- ✓ 100% stainless steel construction

Surface aerator...

but in name alone.

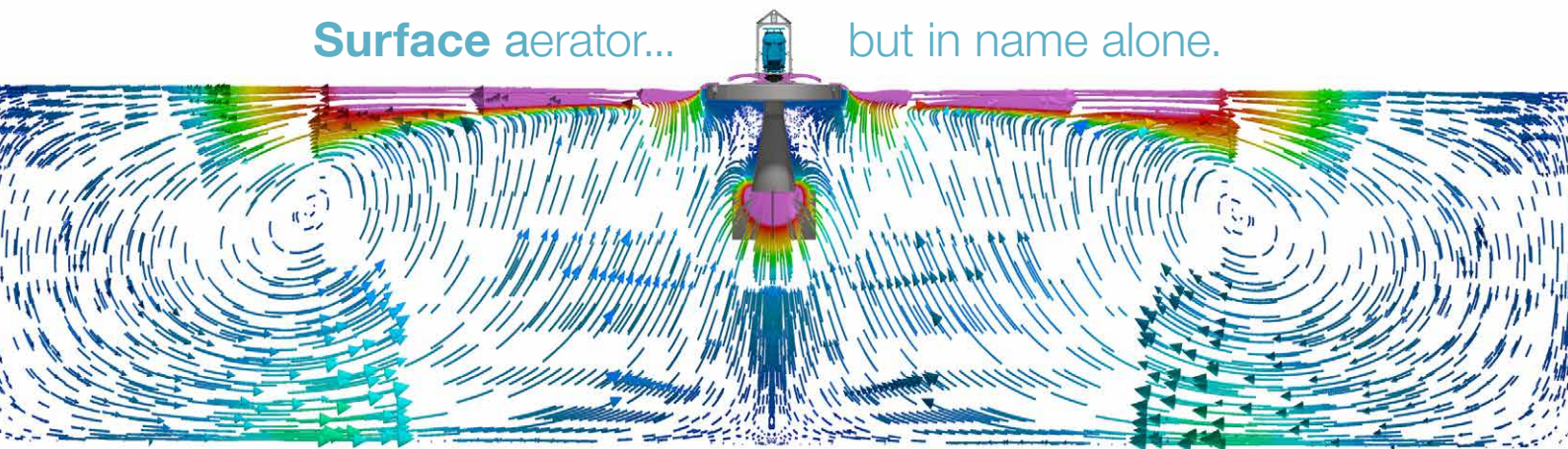

Features

High-efficiency Motor

WEG W22.
Built to aeris.global specifications

Four-function Lifting Saddle

Power section swivel feature

Replaceable Mooring Eyes

Cast stainless steel

Anti-vortex Vanes

Cone-cross

Infinite draft options to suit any water level

Soft-edge Liner Base (Optional)

Designed to protect membrane liners

screwPELLER®
Direct-mount with no support bearing required. Integral rotating diffusion head

Large Stabilisation Cross

100% Stainless Steel Construction

Anti-erosion Plate (Optional)

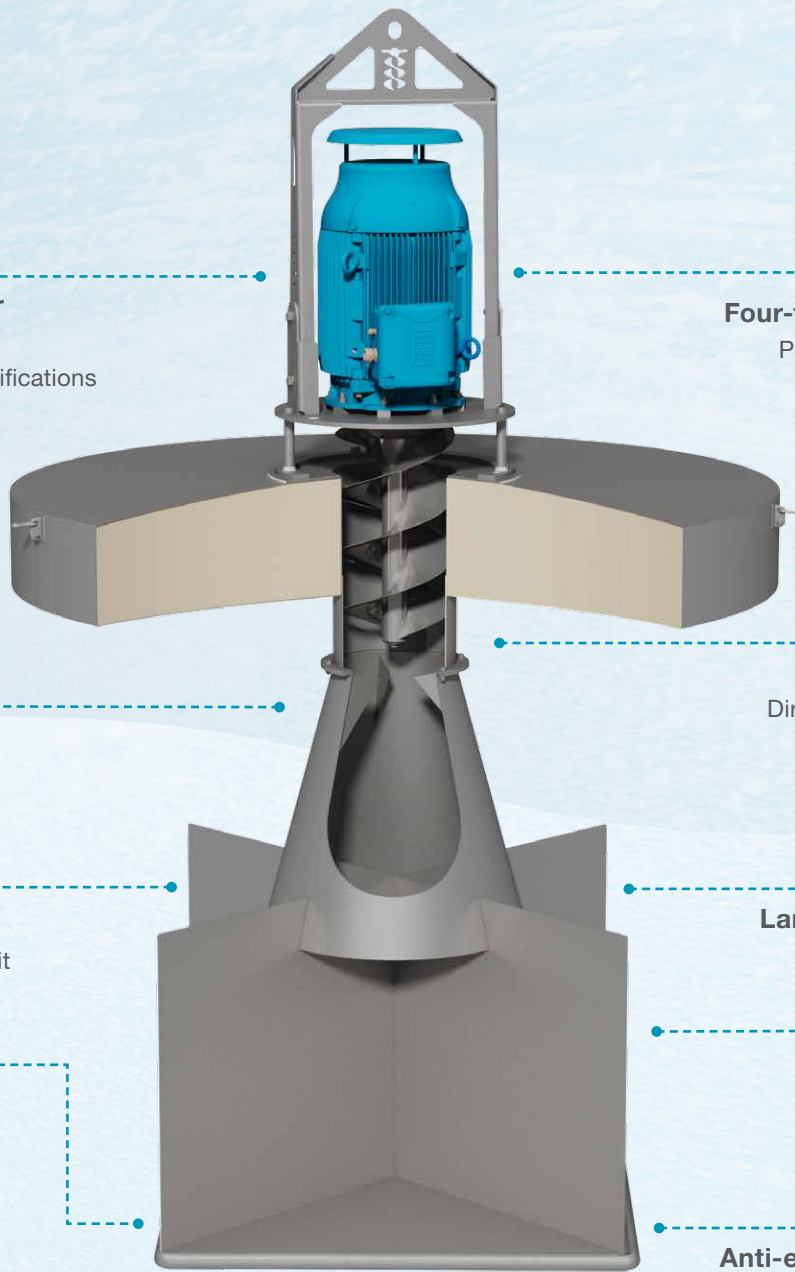

Four-function Lifting Saddle

1

Lift entire aerator
For installation and removal

2

Lift without cone-cross
For assembly and disassembly

3

Lift power-section only
For assembly and disassembly

4

Swivel power-section
Perfect COG allows rotation by hand

Why do aquaturbo® AER-AS Surface Aerators perform so well in wastewater?

In general oxygen transfer to micro-organisms in wastewater occurs in two phases.

- PHASE ONE** Transfer from the air to the liquid part of the activated sludge mixture
- PHASE TWO** Transfer from the liquid to the micro-organisms in an activated sludge floc

aquaturbo® AER-AS is designed to achieve maximum efficiency in both phases.

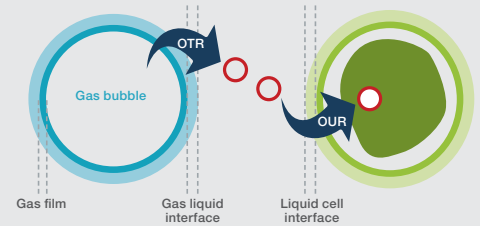

Above: Air to liquid phase and Liquid to micro-organism phase.

PHASE ONE

The OTR (Oxygen Transfer Rate) from air to water occurs by Molecular Diffusion and is influenced by the following:

1 Contact Area

Oxygen transfer only takes place at the contact surface between air and water; typically, in three forms:

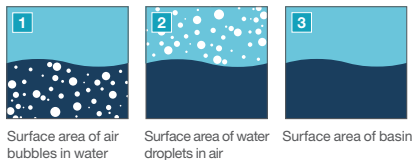

2 Contact Area Renewal

Oxygen transfer is not only influenced by the size of the contact area, but also the rate of contact area renewal. The water at the boundary layer becomes saturated almost immediately upon exposure to air. The primary function of a high-performing surface aerator is to achieve fast and continuous renewal of the contact area. This allows activated sludge with a low DO to be drawn into the aerator before being transformed into an oxygen-rich discharge.

3 Oxygen Deficit

Oxygen deficit is the difference between actual oxygen content and the saturation value of the water. The greater the difference the greater the Oxygen Deficit. Maximum deficit is met when the actual oxygen content is zero. The easiest oxygen to transfer and the highest rate of transfer occurs when oxygen deficit is greatest and therefore DO concentration is at its lowest. The rate of oxygen transfer is inversely proportionate to DO concentration.

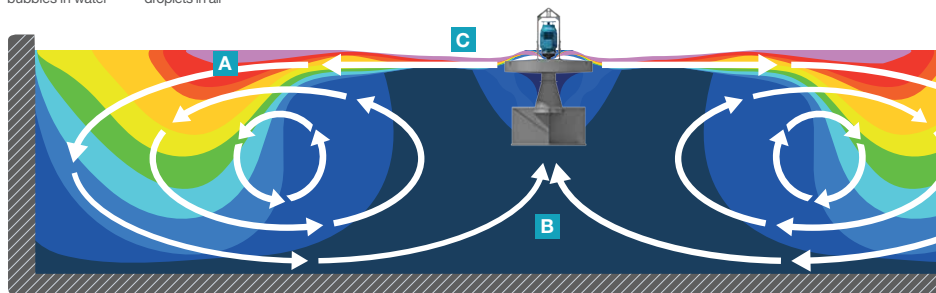

A Highest DO; Lowest O₂ deficit B Lowest DO; Highest O₂ deficit C Zone with highest rate of O₂ transfer

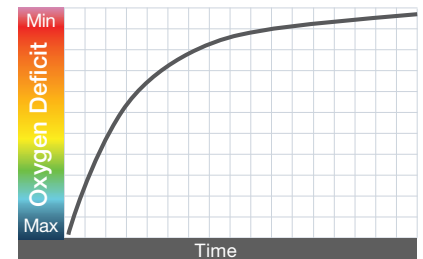

Rate of oxygen transfer versus oxygen deficit

PHASE TWO

The OUR (Oxygen Uptake Rate) from liquid to the activated sludge flocs occurs by Convective Diffusion and is influenced by the following:

1 Contact Area

Due to high velocities and high microturbulence, activated sludge flocs are divided into smaller flocs resulting in a greater contact surface area.

2 Velocity between exchanging particles

High exit flow velocity creates high turbulence on the surface and a high microturbulence within the basin. Here we distinguish between two sub-phases:

1. Passage through the air:

The high exit velocity produces very small water droplets and consequently the activated sludge flocs are surrounded by a very thin liquid layer.

2. In the aeration basin:

The microturbulence within the basin induces very rapid movement of the small flocs in all directions.

3 Driving Force

The difference in oxygen concentration between activated sludge flocs and surrounding liquid. Here, we distinguish between three sub-phases:

1. Passage through the air:

The activated sludge flocs are pumped up from the bottom of the aeration basin and are almost, if not fully, anoxic. They are brought in contact with ambient saturated air. The driving force at 10°C is 9.17mgO₂/l versus 0 to 0.5mg/l ensures a rapid transfer of oxygen to activated sludge flocs.

2. In the aeration basin:

The microturbulence induces very fast movement of the micro-organisms; this, combined with the large contact surface makes more effective transfer of oxygen to micro-organisms.

3. Transitory phase:

Between sub-phase 1 and 2 we have a transitory phase 3, at the water surface. The impact from the aerator spray on the water surface induces hydraulic jump and thus surface renewal.

Activated sludge flocs are smaller with aquaturbo® AER-AS (Typ. 10 to 50µm) compared to other forms of aeration so oxygen can easily penetrate the centre of the floc. This results in two advantages:

1. The entire floc is aerobic, so we benefit from its maximum biological activity.

2. aquaturbo® AER-AS does not need a "high partial pressure" in the aeration basin to penetrate the floc membrane. The energy gain due to this is very clear when we compare for example 0.5 and 2mg/l as residual oxygen levels without changing the other parameters. $(9.17 - 0.5) / (9.17 - 2.0) = 1.2$ so 20% aquaturbo® AER-AS is designed for real conditions in activated sludge.



screwPELLER®

The key to aquaturbo®
AER-AS success

Every performance advantage of the aquaturbo® AER-AS surface aerator stems from the screwPELLER® action. It is a centrifugal impeller using a two-start Archimedean helix with an integral top plate designed to perform multiple functions as follows:

- The high velocity discharge hits the water surface at a low impact angle resulting in virtually all kinetic energy being transmitted to the water surface. This means the water surface is rapidly renewed so water with low oxygen concentration is brought into contact with air. The exceptionally high Renewal Rate at the contact surface capitalises on the principle of Oxygen Deficit (Ref. Opposite).
- Creates enormous oxygen dispersion diameters.
- Horizontal velocity “injects” the discharge back into the basin and, in-doing-so, maintains control over the velocity so aerosol and odour drift are mitigated.
- Exceptional pumping efficiency is close to that of a volumetric screw pump and the gentle action of the sweeping flights minimises damage to delicate flocs.
- Minimises hydraulic losses from the instantaneous change in direction from axial suction flow to radial discharge flow.

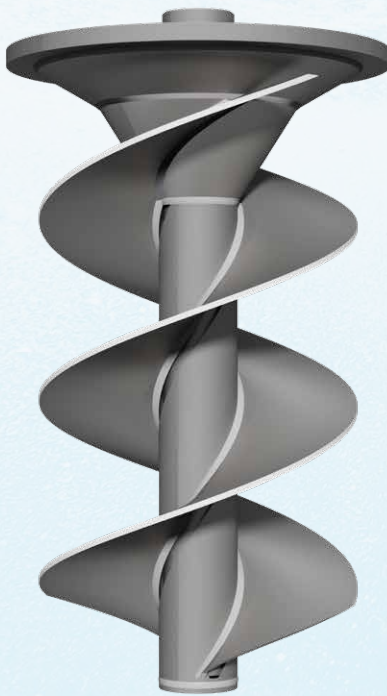

Below: CFD image showing change in oxygen concentration in accordance with continuous contact area renewal generated by the screwPELLER® action.

- Pumped flow impacts the plate during the change of direction and in doing so equalises axial loadings on motor bearings.
- Prevents water entering the motor by acting as a slinger plate.
- The reason for the top plate being far heavier than is required to redirect the flow is to position the centre of rotating mass as close as possible to the drive-end motor bearing.
- The combined benefits of the screwPELLER® design allow all electric motors to be installed with standard bearings.
- The one-piece stainless steel impeller eliminates support bearings, wear sleeves and couplings along with all associated maintenance issues.
- The high horizontal velocity at the surface creates a cylindrical mixing pattern moving upper and lower laminar layers in opposite directions creating laminar shear and mid-layer rotation. This mixing pattern maximises bubble dwell time by inhibiting the natural path of bubbles to the surface.

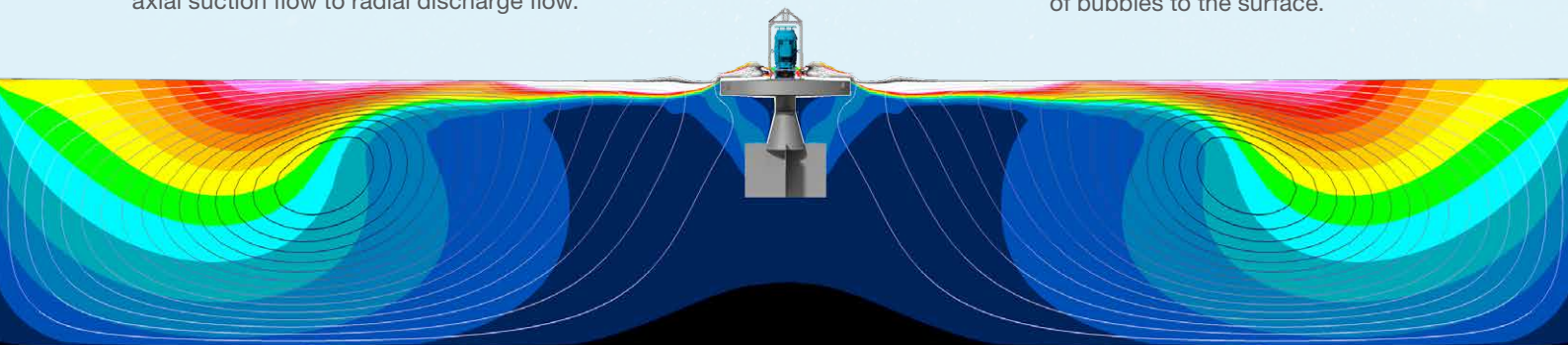

aquaturbo® AER-AS Model Range

Operational Water Levels + Zones

Model Designator

Example: **AER-AS 3000-24**

AER-AS = Floating Surface Aerator

3000 = 30kW **24** = 4-Pole, ±1500rpm

WATER LEVELS

MODEL	kW	rpm	1*	2*	3	4
			m	m	m	m
SERIES 24 4-Pole, ±1500rpm						
AER-AS 0075-24	0.75	1455	0.63	0.98	1.80	2.80
AER-AS 0110-24	1.1	1460	0.69	1.00	1.90	2.90
AER-AS 0150-24	1.5	1455	0.71	1.05	2.05	3.05
AER-AS 0220-24	2.2	1440	0.74	0.98	2.20	3.20
AER-AS 0300-24	3	1440	0.74	1.06	2.40	3.40
AER-AS 0400-24	4	1450	0.80	1.11	2.50	3.50
AER-AS 0550-24	5.5	1465	0.85	1.26	2.60	3.60
AER-AS 0750-24	7.5	1465	0.90	1.33	2.80	3.80
AER-AS 1100-24	11	1470	1.00	1.46	3.00	4.00
AER-AS 1500-24	15	1470	1.08	1.53	3.20	4.70
AER-AS 1850-24	18.5	1470	1.10	1.73	3.30	4.80
AER-AS 2200-24	22	1475	1.10	1.83	3.40	4.90
AER-AS 3000-24	30	1480	1.20	2.14	3.60	5.10
AER-AS 3700-24	37	1480	1.24	2.08	3.80	5.30
AER-AS 4500-24	45	1480	1.26	2.16	3.90	5.40
AER-AS 5500-24	55	1480	1.38	2.30	4.00	5.50
SERIES 16 6-Pole, ±1000rpm						
AER-AS 0750-16	7.5	975	1.00	1.45	2.90	3.90
AER-AS 1100-16	11	975	1.09	1.68	3.10	4.10
AER-AS 1500-16	15	975	1.10	1.75	3.30	4.80
AER-AS 1850-16	18.5	975	1.15	2.11	3.40	4.90
AER-AS 2200-16	22	980	1.20	2.13	3.55	5.05
AER-AS 3000-16	30	985	1.20	2.17	3.80	5.30
AER-AS 3700-16	37	985	1.26	2.28	3.90	5.40
AER-AS 4500-16	45	990	1.35	2.35	4.05	5.55
AER-AS 5500-16	55	990	1.49	2.47	4.20	5.95
AER-AS 7500-16	75	990	1.60	2.86	4.50	6.25
AER-AS 9000-16	90	990	1.60	3.05	4.65	6.40
AER-AS 11000-16	110	990	1.90	2.95	4.80	6.55
AER-AS 13200-16	132	990	1.90	2.93	5.00	6.75
SERIES 12 8-Pole, ±750rpm						
AER-AS 3700-12	37	740	1.49	2.39	4.20	5.70
AER-AS 4500-12	45	740	1.53	2.47	4.35	5.85
AER-AS 5500-12	55	740	1.79	2.89	4.55	6.30
AER-AS 7500-12	75	740	1.85	2.99	4.80	6.55
AER-AS 9000-12	90	740	2.10	3.41	5.00	6.75
AER-AS 11000-12	110	745	2.14	3.46	5.20	6.95
AER-AS 13200-12	132	745	2.25	3.64	5.40	7.15
AER-AS 16000-12	160	745	2.32	3.76	5.60	7.35
AER-AS 20000-12	200	745	2.39	3.89	5.90	7.65

ZONES

A*	B	C
m	m	m
2.5	7	20
3.5	8	24
4.5	9	28
5.5	12	45
6.5	13	45
8	14	47
9.5	15	49
10	16	52
10.5	19	61
11	22	70
11.5	24	75
12	25	80
13	25.5	86
14	26	90
15	26.5	95
16	27	100
10.5	18	51
11.5	20	63
12	23	72
12.5	25	78
13	27	84
14	31	95
14.5	33	100
15	35	107
15.5	40	116
16.5	44	128
17	46	137
17.5	50	143
18	52	145
15	34	103
15.5	36	110
16	41	119
17	46	128
17.5	49	135
18	53	144
18	57	150
18.5	60	154
19	62	157

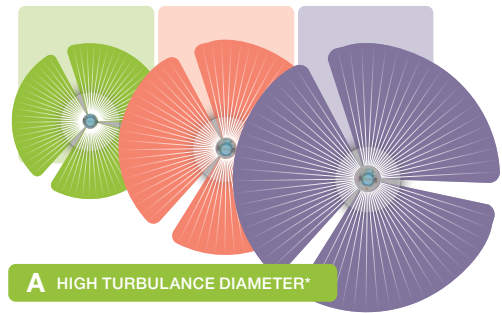
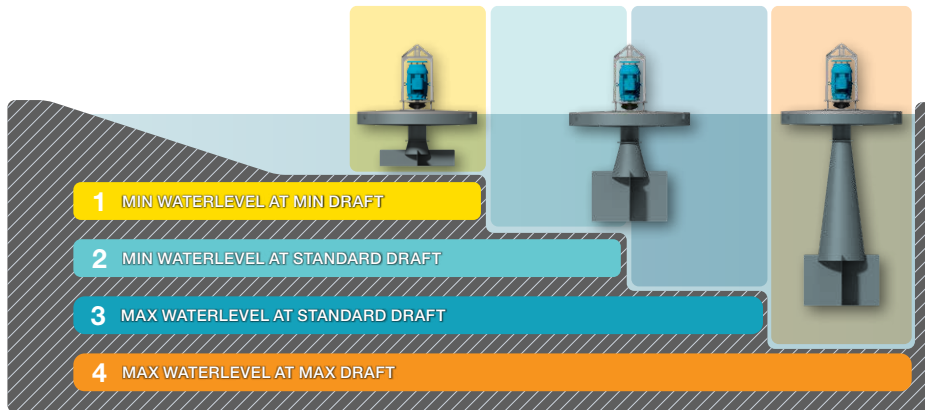

- A** HIGH TURBULENCE DIAMETER*
 - B** COMPLETE MIX DIAMETER
 - C** OXYGEN DISPERSION DIAMETER
- * Zone A is min basin diameter and min aerator centres.

* * Min water levels 1 and 2 are draft plus 0.1m

Please note: Final aerator selection and exact draft is dependent upon many factors including basin construction (concrete, earthen, membrane liner or other), water level fluctuation; nature and degree of settled deposits, process objectives (complete mix, partial mix, laminar mix or other) and whether the influent is screened. An Anti-erosion Plate is often specified for operation in shallow earthen or membrane lined basins and when settled deposits are present.

Please note: Zones A, B and C are average values depending on basin dimensions, water levels, solid concentration, operational hours per day and reactor configuration.

Standard Specifications

Motor

- WEG W22 custom manufactured to aeris.global specs
- IEC 72 Standard, V1 Mount (Flange Only)
- IP66, Rain Cap, Insulation Class-H (B Temp Rise), Thermistor Type PTC, Space Heater (200-240V)
- E3 Premium Efficiency (Exceeds AS/NZS 1359.5:2004 Table B2 Minimum Energy Performance Standards)
- WEG Triple Epoxy Paint Plan 212E (aeris.global colour)

Construction

- AISI 304L stainless steel
- Closed-cell polyurethane foam filled float
- Four-function lifting saddle c/w power-section swivel feature
- Three mooring eyes @ 120-degrees

Replaceable Mooring Eyes (standard)

Aerators secured in place with mooring cables have eyes on the float for cable connection. Over time the eyes can wear particularly in high-energy basins, high kW models, multiple start operation and on basins exposed to high wind.



Optional Specifications

Motor

- Alternate WEG paint plans and colours upon request
- WEG W3Seal® with brass labyrinth seal for ultimate ingress protection
- Tropicalised Windings – Internal paint system
- AEGIS® SGR Bearing Protection Ring (Grounding Ring)
- VibePro24/7 online wireless vibration and temperature monitoring system
- Alternate IEC motors available upon request

Anti-erosion plate

- For use in shallow, earthen constructed and membrane lined basins. Eliminates draw from directly below the axis of rotation and promotes horizontal suction from the laminar layers above the level of the plate.

Construction

- Reduced or extended draft variations to suit water level
- Four mooring eyes @ 90-degrees
- Alternate materials of construction – AISI 316L stainless steel; duplex stainless steel upon request
- Special cone-cross options to suit application – e.g. flow through design for oxidation ditch and annulus installations

Soft-edge liner base

- For use in membrane lined basins. Designed to prevent damage to the liner in the event of inadvertent contact or to allow the aerator to rest on the liner if the basin is lowered or drained.

Infinite Draft Options

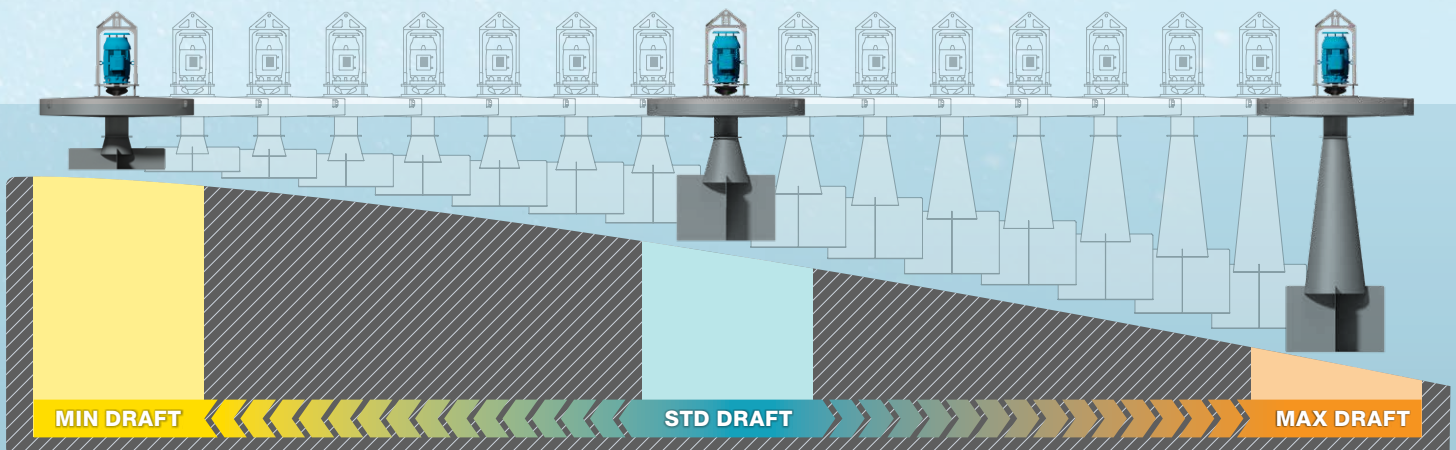

Each aquaTurbo® AER-AS surface aerator has a standard draft with an associated min and max water level range. The draft can be reduced or extended within the operational limits of each model. Optimum mixing and oxygen transfer are achieved when the correct draft is selected to suit the water level.



Accessories



Electrical Control

Typical control options include DOL starter, soft-starter, Variable Frequency Drive, thermal overload protection, auto reversing and vibration sensing.



Debris Limiter

Prevents ingress of large foreign objects such as traffic cones, hardhats and wooden blocks. The orifice size limits entry to objects small enough to easily pass through the [screweller](#). The Debris Limiter is not a screen and therefore not intended to prevent ingress of hair or fibre.



Remote Greasing / Lifting Sling

Allows re-greasing of motor bearings from outside the basin or from the safety of an [otterpontoon](#) – Safe Access Platform. Typically fitted to aerators mounted on swing-arms where the aerator can be rotated adjacent the basin wall for service. Also allows easy crane connection from outside the basin.

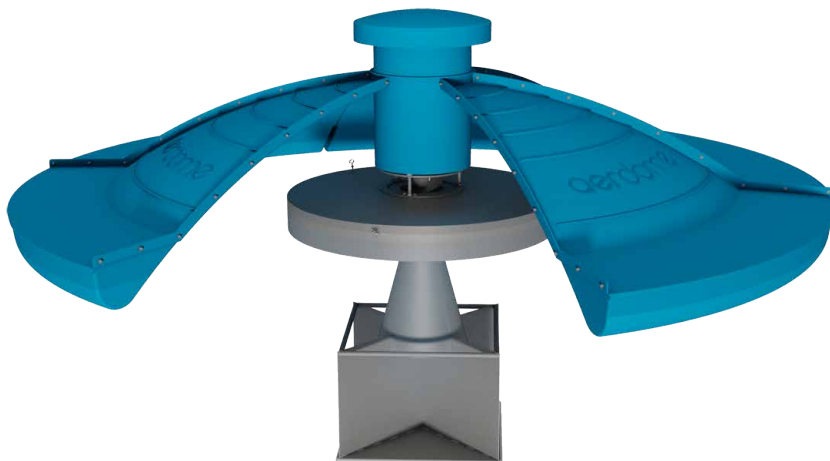

aerodome® Cover

Exceptional performance but used only on sites with the most extreme sound pressure and/or odour limits. Buoyancy is independent of aerator. Segmental design and FRP construction allow ease of transport and installation.



Spray Deflectors

Generates lower profile spray for aerators exposed to high-wind and/or operating in sensitive environs. Reduces cooling effect by suppressing airborne flight of spray.



Equipment Identifier

Double-sided, clip-on, laser cut plastic panel designed to allow easy identification of equipment from the shore.



Cable Floats Clamps

Designed to suspend 1, 2 or 3 electrical cables of any size on mooring cable sizes from 4 - 10mm dia. beneath Type A, B or C Cable Floats.

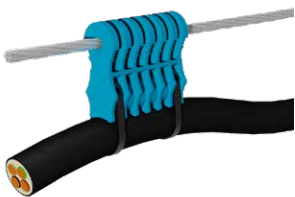

Cable Hanger

Designed to suspend 1, 2 or 3 electrical cables of any size on mooring cable sizes from 4 - 8mm dia. Allows independent linear movement.

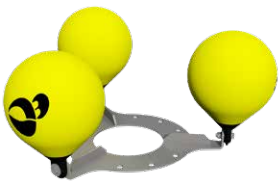

Floating Junctions

Multi-cable junctions available as single-float or tri-float versions in 304L or 316L construction. Options to suit Type A, B or C Cable Floats



Cable Floats

Lay-flat, inflate on site, spherical floats moulded in tough UV-resistant PVC. Three buoyancy options:
Type A – 20kg; B – 44kg; C – 82kg

Mooring Cables

4, 6, 8 & 10mm dia. 316 Stainless steel cables complete with INOX stainless steel ferrules, thimbles, rope grips, shackles and Quicklinks.

Electrical Cables & Glands – Power, PTC, Space Heater

Siemens OZOFLEX (PLUS) heavy-duty submersible, multiple options

Purpose-designed, relocatable post and pile system provides universal attachment for all aercable® accessories. Three versions to suit a wide range of mooring forces; laser-cut, hot-dip galvanised mild steel construction. Slotted flange connection allows radial adjustment for perfect alignment. Non-standard designs and stainless-steel versions upon request. Optional excavation-free Ground Screw allows same-day utilisation

A Cable Management Spool Ref. Docking Cable

Designed to safely store, dispense and retrieve surplus cable required for aerator repositioning.

B Standard Bracket

Multiple mooring cable connection points. Incorporates swivel mounting for single and double-spools.



C Swing-arm Yoke Attachment Bracket

Directional aerators and mixers are typically swing-arm mounted. The Yoke Attachment Bracket is designed to allow connection of the fully-articulated swing-arm yoke as well as providing multiple mooring cable connection points.

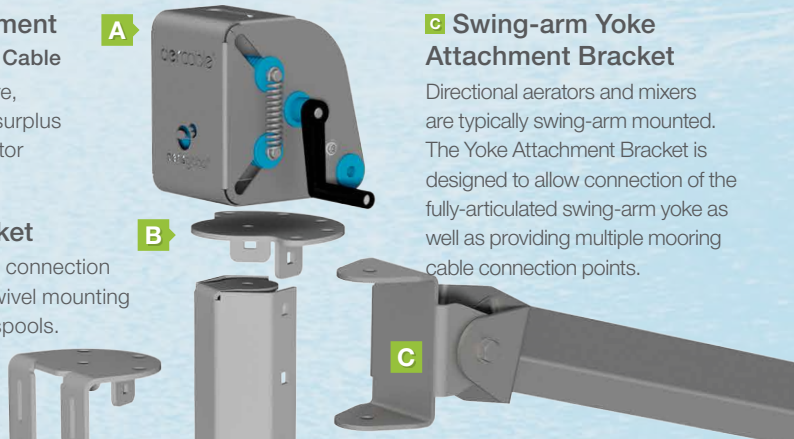

F Adjustable Bracket

Allows attachment of Mooring Cable, Strain Relief and Quick-release Connectors at 100mm increments.

D Electrical Junction Box Mounting Bracket

Mounting bracket allows attachment of virtually any electrical enclosure as well as providing multiple mooring cable connection points.



E Universal Anchor Post

Anchor Post is the core component of the system. It provides attachment of all bracket options. The Adjustable Bracket can be attached at 100mm increments. Standard Bracket, Yoke Attachment and Junction Box Brackets connect only to the top of the post.

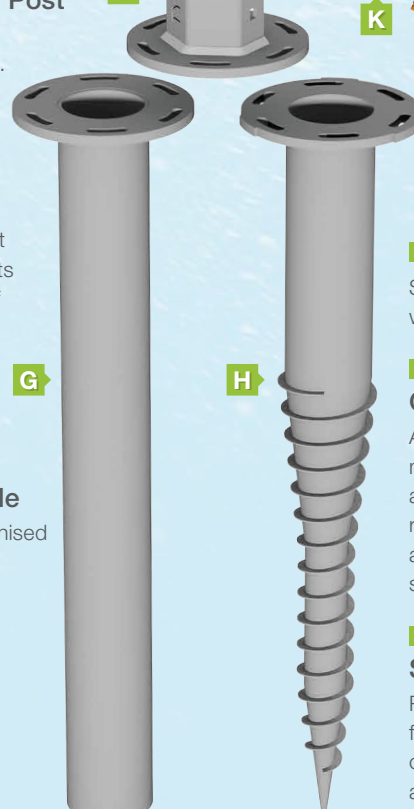

G Standard Pile

Set-In-Place, hot-dip galvanised mild steel pile.

H Ground Screw Pile

Self-drilling, hot-dip galvanised mild steel pile.

- No digging or concrete required
- Mooring forces can be applied immediately
- Fast and inexpensive to remove and relocate

I Mooring Cable

Stainless steel cables complete with all installation hardware.

J Quick-release Connector Ref. Docking Cable

Allows partial release of mooring cables to reposition aerator for access. Upon reconnection aerator is automatically returned to its pre-set, normal operating position.

K Electrical Cable Strain Relief

Relieves strain on cables from being transferred to cable connections, glands and junction box.



Installation Systems

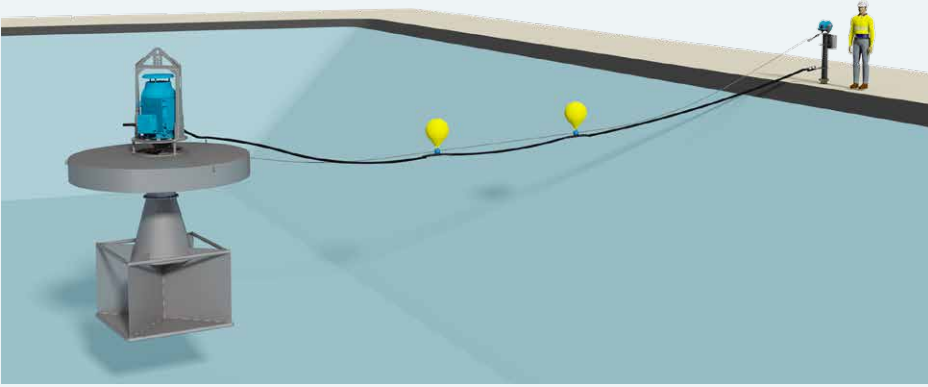

Mooring cable

The most common installation method. Either three or four cables locate the aerator in a fixed X-Y position. The cables are not tensioned and therefore allow moderate water level variation. Mooring cables can be connected to a variety of anchors posts and wall brackets. The power cable is typically suspended on one of the mooring cables using [aercable® Cable Hangers](#) and/or [Cable Floats](#).

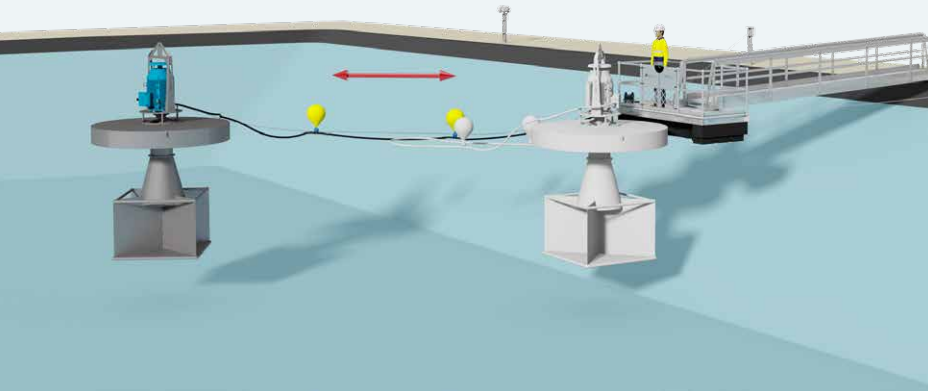

Docking Cable

C/w Quick-Release Connector

Allows personnel to partially disconnect one or more of the mooring cables using an [aercable® Quick-release Connector](#) and move the aerator from its normal operating position to any accessible docking position or to an [otterdock® - Safe Docking Platform](#). Following maintenance, the aerator automatically returns to its original operating position simply by re-attaching the [aercable® Quick-release Connector](#).

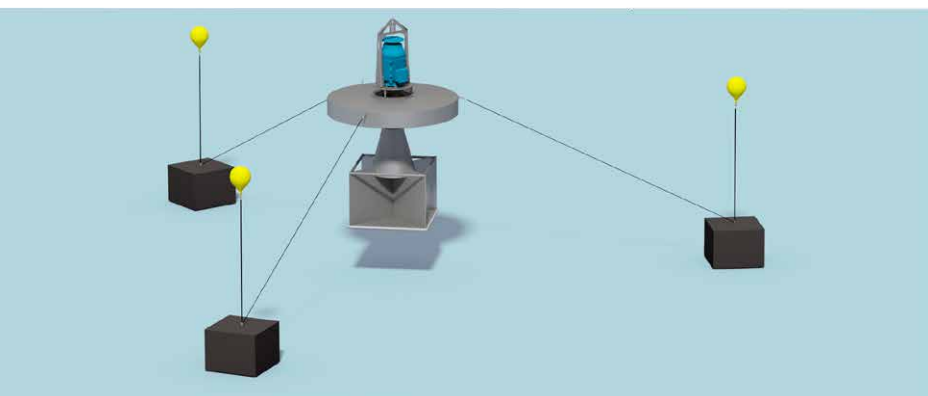

Floor Anchor

This method is selected when the distance to shore prevents the use of standard mooring cables. The aerator is moored to either three or four concrete anchors resting on the basin floor. A buoy affixed to each anchor identifies its position and supports a lifting chain for ease of retrieval.

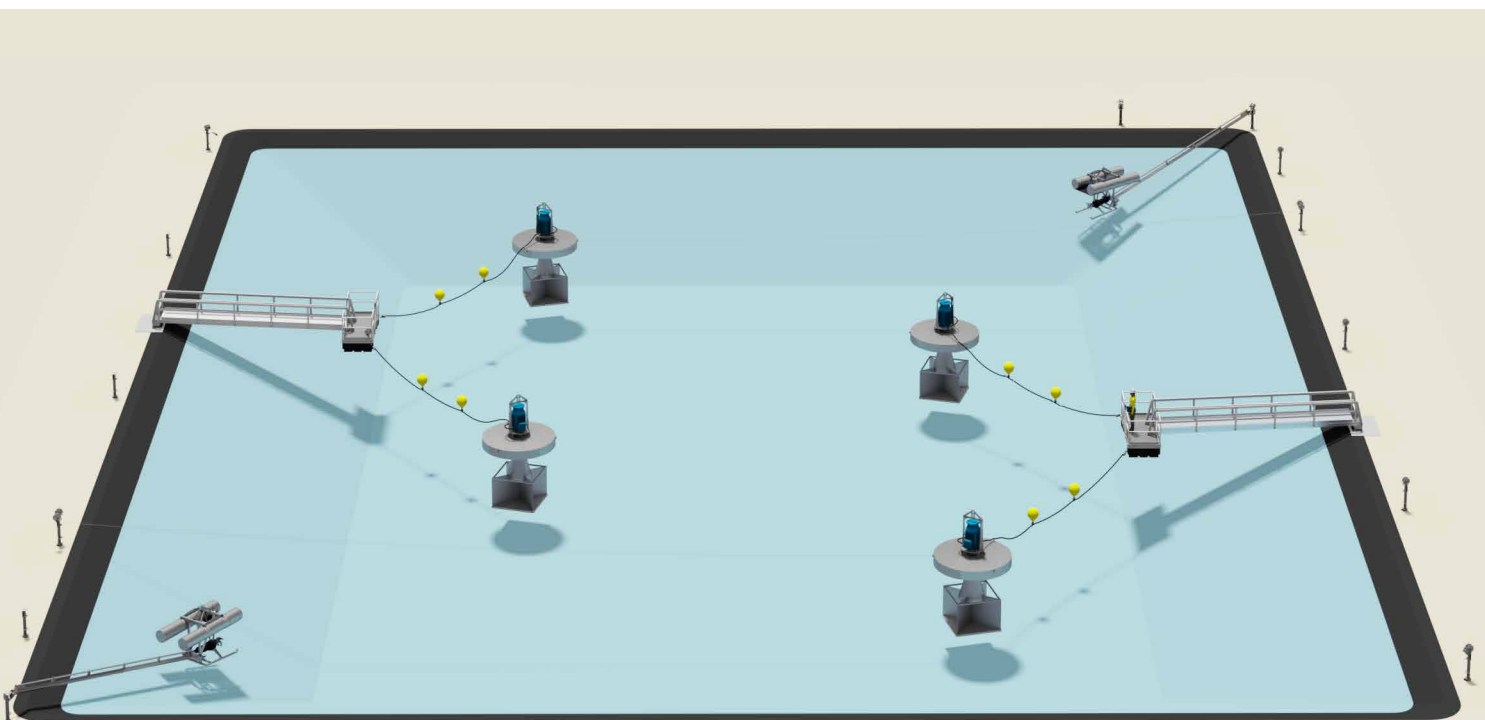

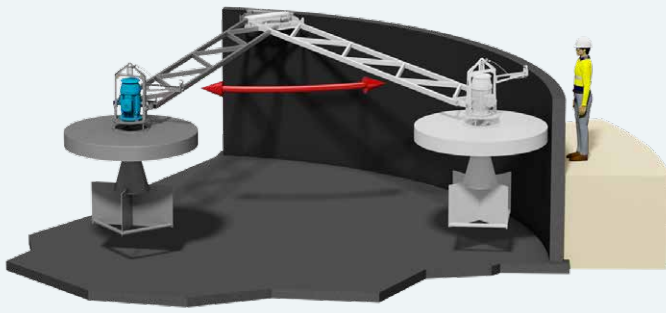

► Swing-arm without stability cables

Full articulated arm design allowing the aerator to rise and fall in accordance with water level variations; swing to the basin wall for service. Common on sites wishing to avoid cables. The swing-arm also acts as a power cable conduit

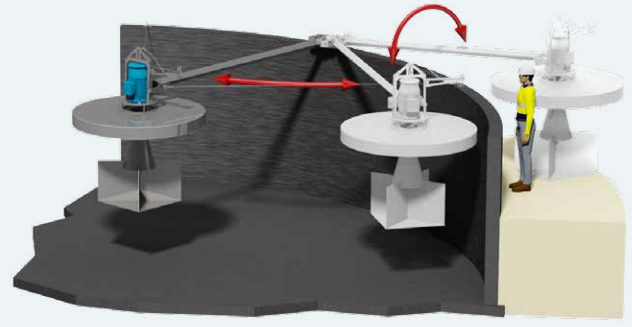

► Swing-arm with stability cables

Full articulated arm design allowing the aerator to rise and fall in accordance with water level variations; swing to the basin wall for service and lift out of the basin for maintenance. The swing-arm also acts as a power cable conduit.

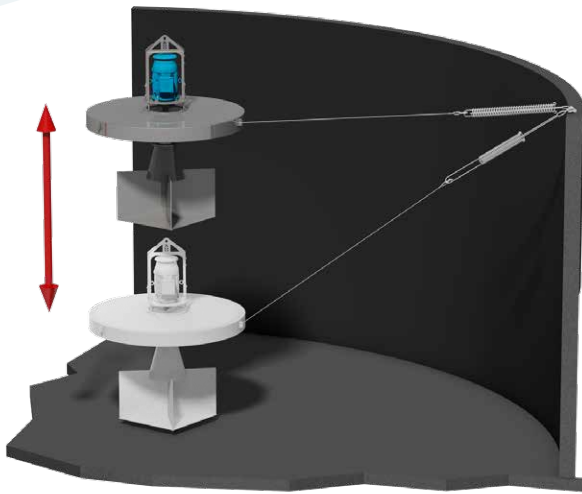

► Mooring Springs

Mooring springs are added for large water level variations when the aerator must remain in a constant XY position. The mooring spring allows for a change in cable length as the water level varies.

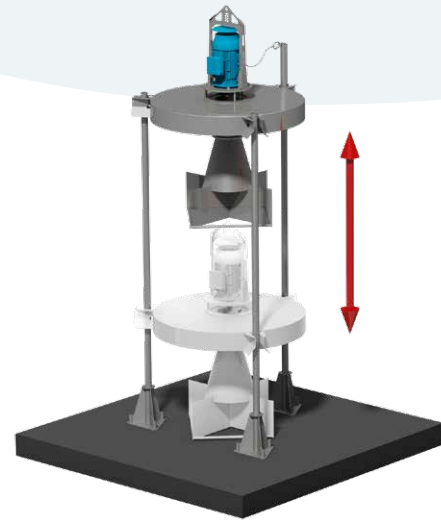

► Guide Rails

Typically selected for applications with a large water level variation but require the aerator to remain in a constant XY position. Common on sites wishing to avoid cables. Aerator installation is simple due to the integral guide rail brackets.

Typical Surface Aerator Combinations

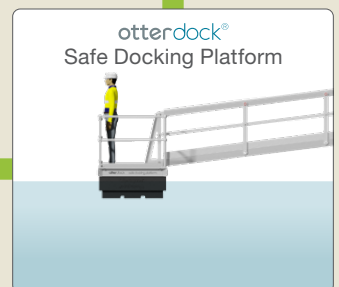
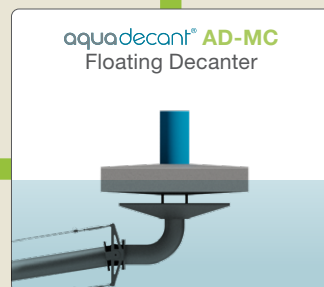
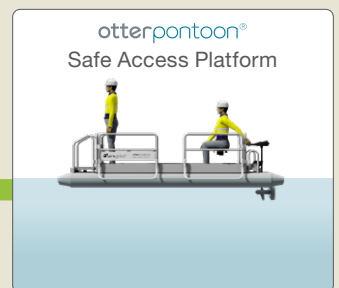

Safety Platforms

In response to a growing awareness of safe work practice around floating equipment aëris.global has developed two new products specifically designed to provide safe and controlled contact with floating aerators and mixers. There is a reluctance by maintenance personnel to use rowboats and on some sites water access is totally prohibited.

otterdock® Safe Docking Platform

Allows personnel to retrieve floating aerators and mixers from their normal operating position and pull to an otterdock® – Safe Docking Platform. This allows housekeeping, service or crane connection to be performed without personnel leaving the safety of the otterdock®. Retrieval is achieved without electrical disconnection. Upon completion, pre-set cable lengths allow the aerator or mixer to be returned to its original position.

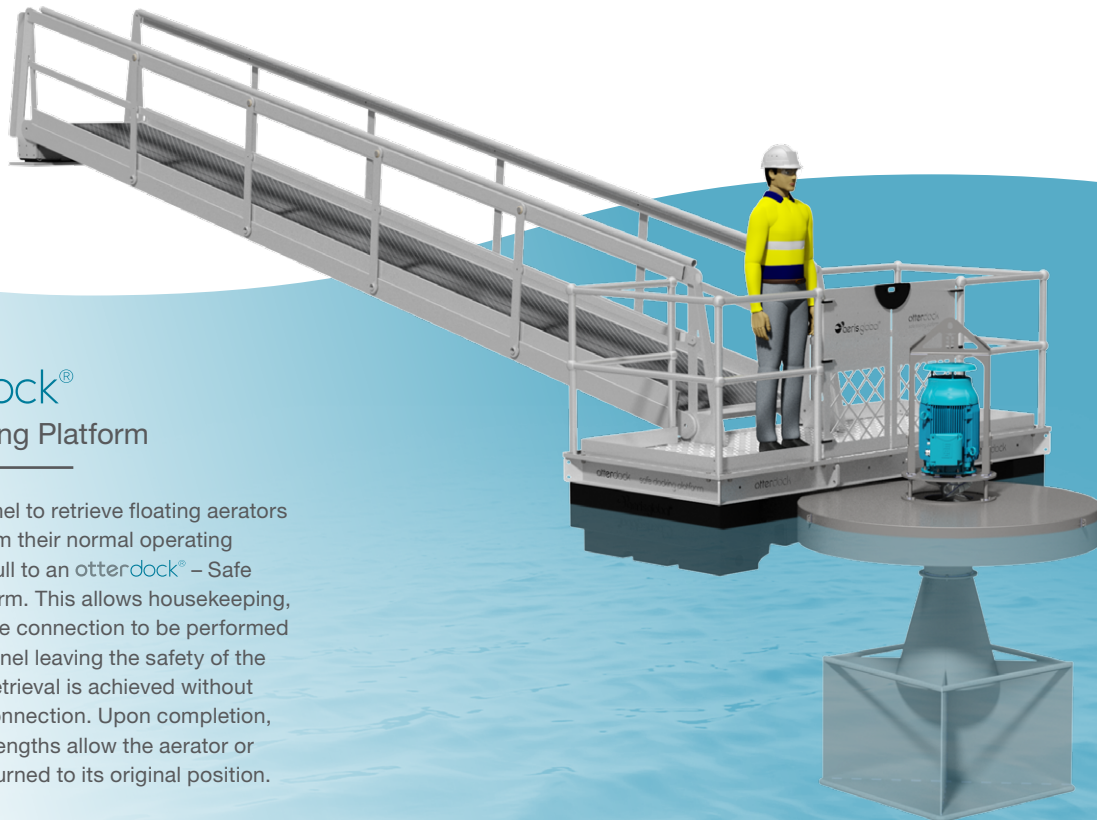

otterpontoon® Safe Access Platform

For those clients happy to work on the water but do not like using a rowboat because of safety and hygiene issues. otterpontoon® – Safe Access Platform, is a highly stable work platform incorporating handrails, rescue rails, non-skid floor, bench seat, tool holders, 24-Volt brushless electric drive, propeller guard and 240V battery management system. otterpontoon® is designed to be moored at an otterdock® but can berth at virtually any jetty.

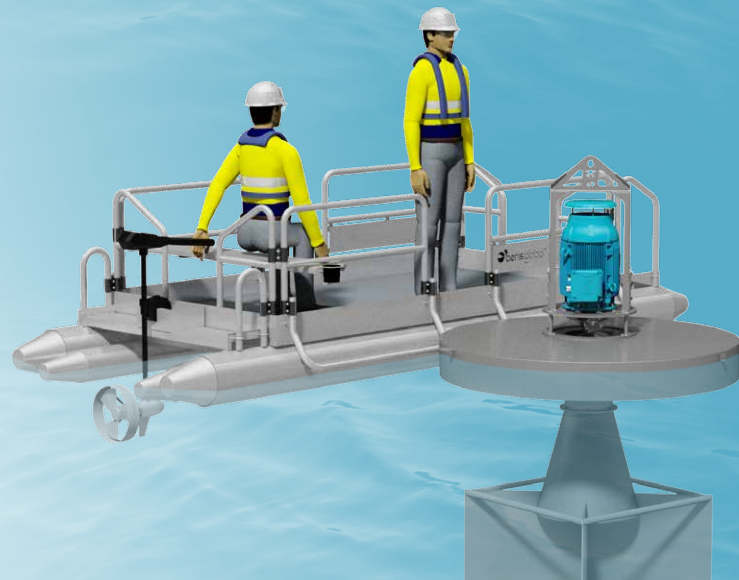

New Zealand

Aëris Global Limited
Ballantyne Ridge Industrial Park,
8 Enterprise Drive, Wanaka 9305
Email: nz@aëris.global

Australia

Aëris Global Australia Pty Limited
Brooklyn Business Park,
37/463A Somerville Road, Brooklyn VIC 3012
Email: au@aëris.global

Disclaimer: While all reasonable care has been taken in the preparation of the content in this catalogue, and at the time of printing and distribution to others the content was deemed to be correct, we accept no responsibility for any errors or omissions discovered subsequent to release even if resulting from lack of reasonable care. Specifications are subject to change without notice. Aëris Global Limited reserve the right to improve the design of any product at any time without assuming obligation to modify any equipment previously manufactured.

Copyright 2023 Aëris Global Limited. All rights reserved.